

- GENERAL NOTES:**
- All dimensions to be checked on site. All details and dimensions relating to sub-Contractors work must be checked and agreed between the sub-Contractor or supplier and the general Contractor.
 - This drawing is to be read in conjunction with all relevant Architect's and Engineer's drawings and specification.
 - The main Contractor is responsible for ensuring the stability of the structure whilst the works are in progress.
 - Any information given regarding existing underground services is given in good faith after consultation with the relevant authority. No liability is accepted by the Consultant and the main Contractor is responsible for obtaining and checking all information and taking due care and attention whilst undertaking the works.

A	03.05.24	AJD	Tracking updated	SRM
REV	DATE	BY	DESCRIPTION	CHK

Issue Status: **PRELIMINARY**

The Civil Engineering Practice
 11 Tungsten Building
 George Street
 Fishergate
 Sussex
 BN41 1RA
 01273 424424
 reception@civil.co.uk
 www.civil.co.uk

CLIENT Bargate Homes Ltd		PROJECT NO. 23066	
PROJECT Land At Beechlands Road, Medstead			
TITLE Refuse Vehicle Swept Path Analysis (10mph)			
DRAWN A Davies	DATE Apr 2024	CHECKED SM	REV 105 A
ENGINEER S Macandrew		SCALE 1:200 @ A1, 1:400 @ A3	

Key:

- Wheel track (Forward manoeuvre) Shows outer limit of wheel entirely within the carriageway. Not encroaching on any kerbs
- Wheel track (Reverse manoeuvre) Shows outer limit of wheel entirely within the carriageway. Not encroaching on any kerbs
- Body track - Shows the outer limit of body generally within carriageway

Phoenix 2 Duo (P2-15W with Elite 6x4 chassis)	Overall Length 11.200m
	Overall Width 2.530m
	Overall Body Height 3.751m
	Min Body Ground Clearance 0.304m
	Track Width 2.500m
	Lock to lock time 4.00s
	Kerb to Kerb Turning Radius 9.500m
	Swept path forward speed 10mph
Large Car (2006)	Overall Length 5.079m
	Overall Width 1.872m
	Overall Body Height 1.525m
	Min Body Ground Clearance 0.310m
	Max Track Width 1.831m
	Lock to lock time 4.00s
	Kerb to Kerb Turning Radius 9.500m
	Swept path forward speed 10mph

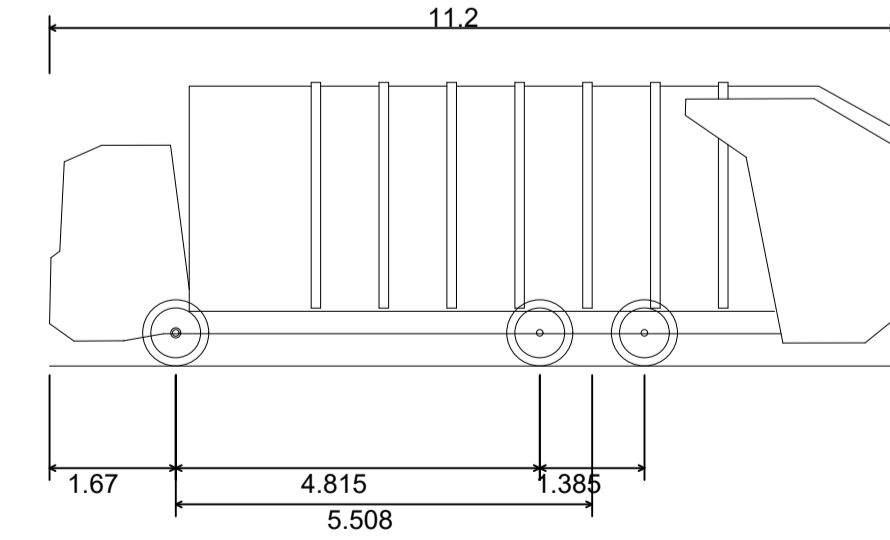

Phoenix 2 Duo (P2-15W with Elite 6x4 chassis)	Overall Length 11.200m
	Overall Width 2.530m
	Overall Body Height 3.751m
	Min Body Ground Clearance 0.304m
	Track Width 2.500m
	Lock to lock time 4.00s
	Kerb to Kerb Turning Radius 9.500m

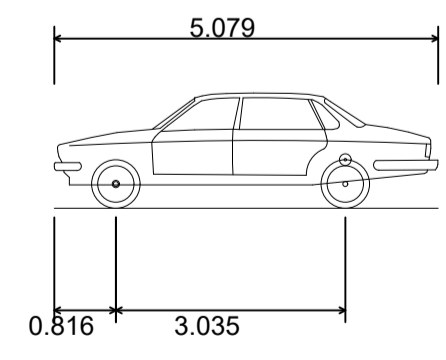

Large Car (2006)	Overall Length 5.079m
	Overall Width 1.872m
	Overall Body Height 1.525m
	Min Body Ground Clearance 0.310m
	Max Track Width 1.831m
	Lock to lock time 4.00s
	Kerb to Kerb Turning Radius 9.500m